



KX^{Large} Series

**5-Axes High Speed Double Column
Vertical Machining Centres**

**Performance
Technology
Power
Accuracy**





KX Large Series

A range of very high performance 5 axes type machining centres for machining of complex parts.

- The choice of portal architecture equipped with forked milling head with 2 rotational axes, rigidity of structure, dynamic of motors and drives, CNC algorithm of the numerical controller, allows high cutting speeds, high federates, high acceleration and jerk. Optical measuring scales contribute to reach high precision.
- High performances in roughing as well as in finishing.
- High accuracy performance in positioning and in 3D contouring.
- Excellent machines for tooling production areas (moulds & dies), aeronautical parts production and precision engineering components.

**KX 50
M / L**

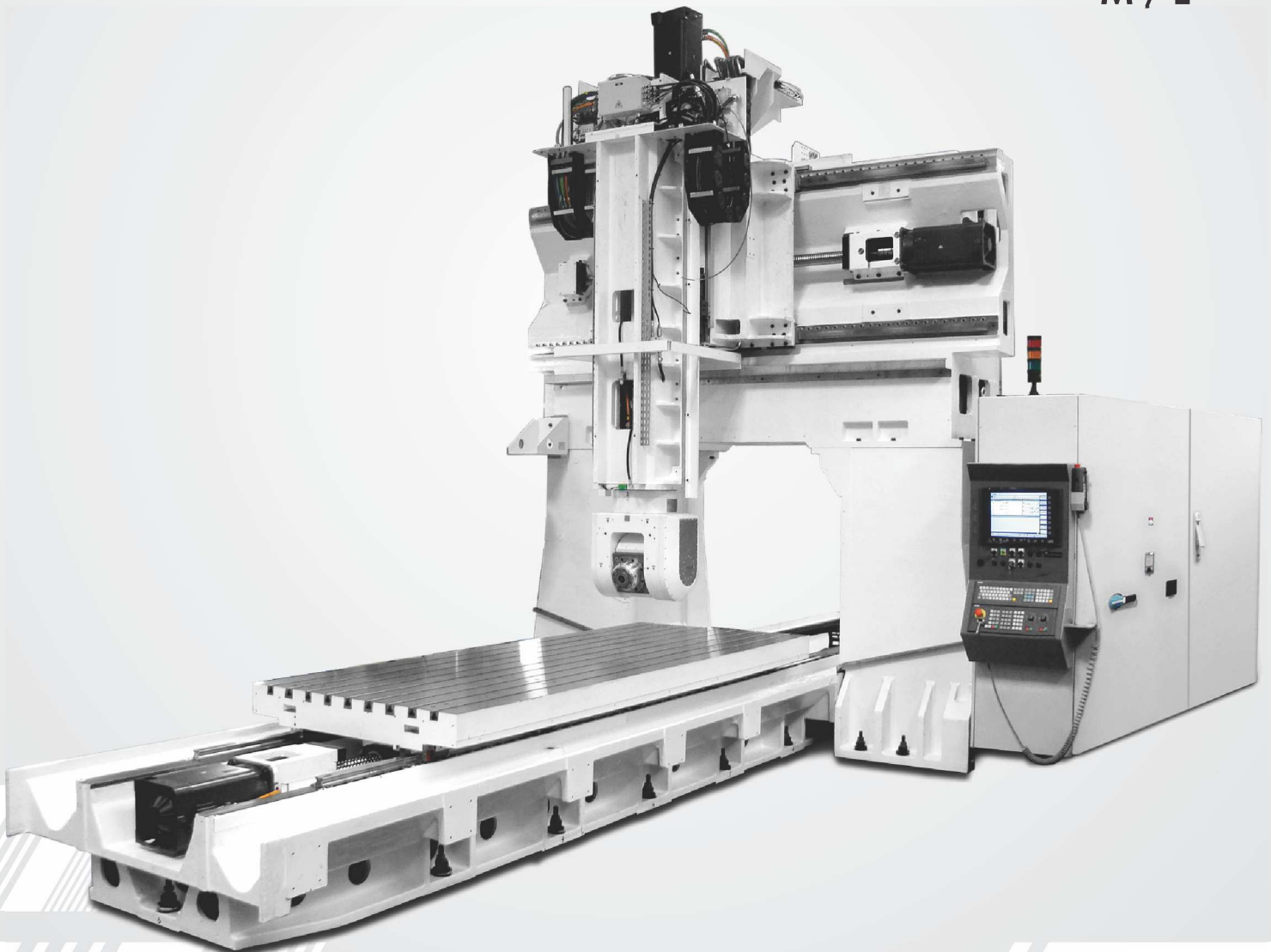



Rotary axes

- For KX Large Series, B & C axes are equipped with angular encoder directly mounted and offer high positioning accuracy. Both the axes have direct driven high torque motors designed specially by Huron to synchronize with all linear axes movements for overall excellent results. This motorization offers the advantages of continuous high speed, high accelerations, high stiffness, no backlash and no wear. The strong clamping and working torque allows machining with high torque for roughing. It also allows machining at high speed into 4 and 5 simultaneous axes.

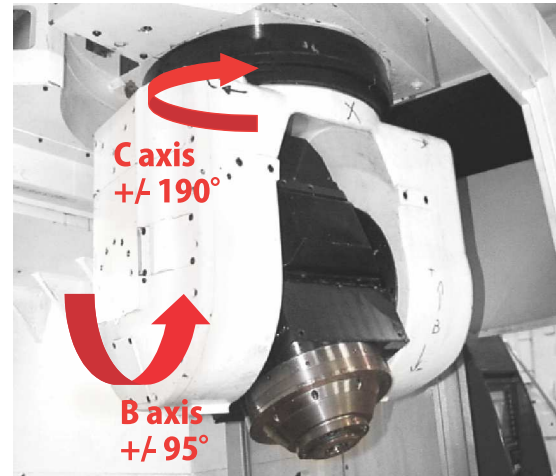

Structure

- Architecture, structure and materials used are optimized to reach an excellent dynamic behaviour in order to be able to absorb the pulsed cutting forces and those induced by accelerations of moving bodies. We thus obtain a great stability and an excellent behaviour during the machining which results in an optimized cut, a great fidelity for the execution of contours and the forms on all types of materials. Life time tool is thus extended.
- Modular machine which adapts with facility to the technical requirements of the customer for an increased productivity.
- Structure with fixed gantry attenuate the torsional stresses, comfortable dimensioning of the static parts and bases of machines. Dynamic parts out of spheroid cast iron.
- Temperature sensors (bench, bearings, spindle) make it possible to control and correct the thermal deformations.

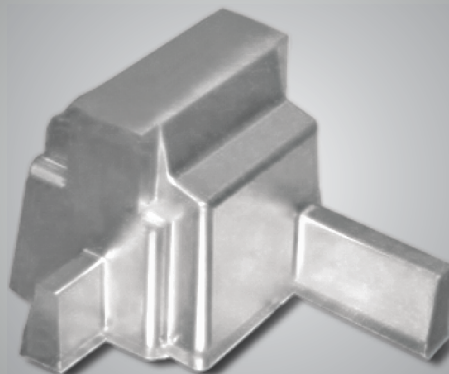
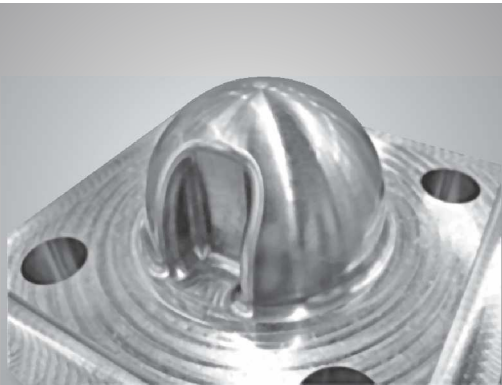



KX Large Series

Standard electrospindle

KX Large Series machines are equipped with high speed 20.000 rpm for KX 50, 18.000 rpm for KX 100 and KX 200 and high power electrospindle as standard. Such a configuration along with synchronization with dynamic parameter capability of machine enables perfect high speed cutting parameters even for complex shaped components with deep cavity workpieces.

Machine can be equipped with several types of spindle in adequacy with the type of application. They offer all a good compromise between power and torque. Accurate HSK attachment is adapted perfectly to the HSM. Positioning and axial/radial stiffness of the tool are guaranteed whatever the efforts on the tool. Machining will be done in full safety condition thanks to the vibration monitoring.

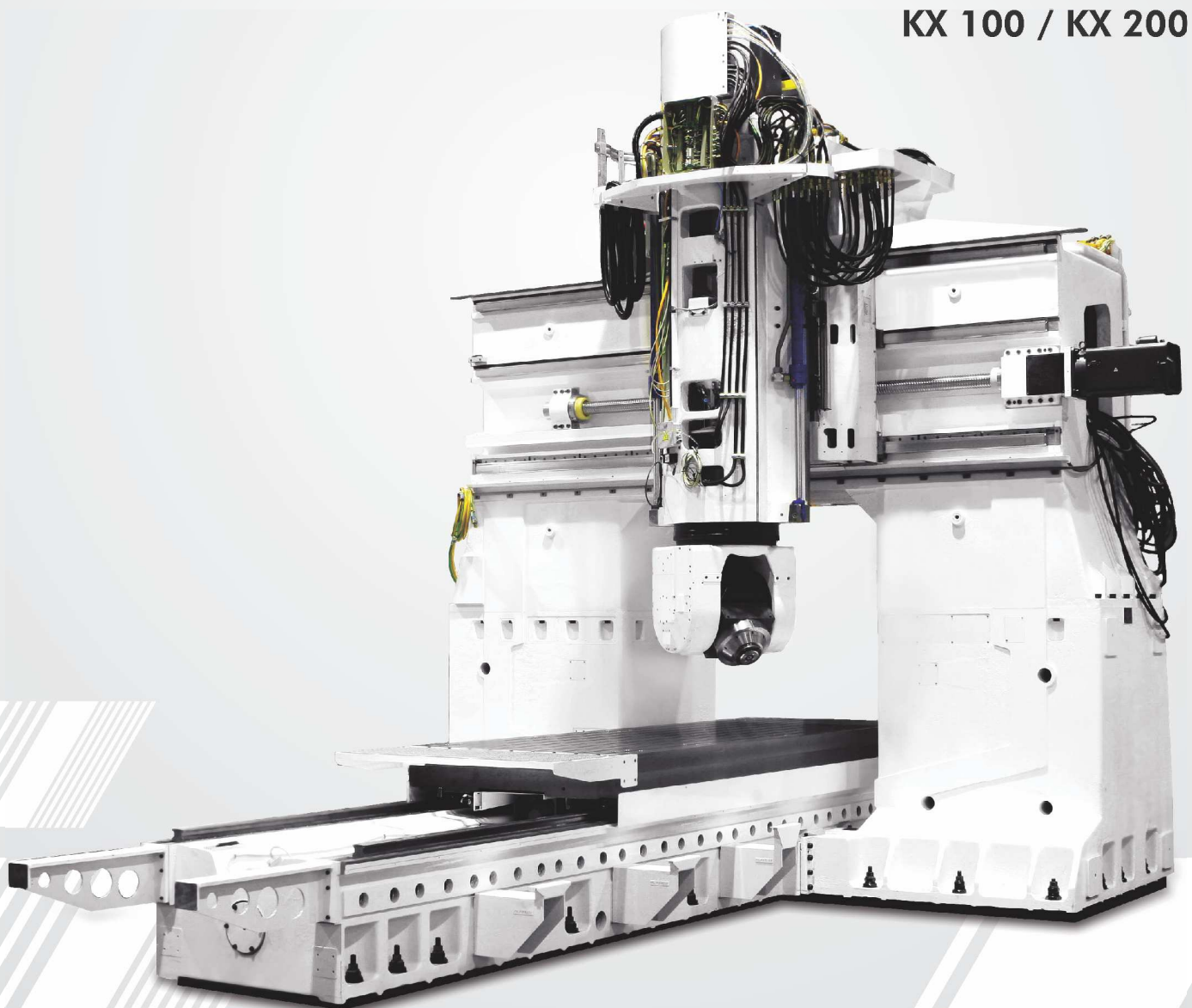

KX 100 / KX 200



Linear axes

- Milling centre with numerical controller, in 5 axes, with fixed gantry.
- X axis : It is as a moving table with wider spacing around both columns for giving a wider working envelop permitting large parts to be machined and a wider range of tool lengths to be used in same set-up.
- Y axis : It is mounted on a traverse supporting the moving saddle.
- Z axis : equipped with orientable milling head with 2 orthogonal rotation axes and an electrospindle. The state-of-art design of Z-axis enables the cutting tool to work on higher parameters of machining even with harder materials with high speed machining.
- Moving elements : slide, saddle, bed and table in cast iron.
- Linear guideways with recirculating roller bearings enable feedrates up to 40 m/min
- Servo-systems : the linear axes are driven by AC motors directly coupled on the end of the precision-ballscrew.

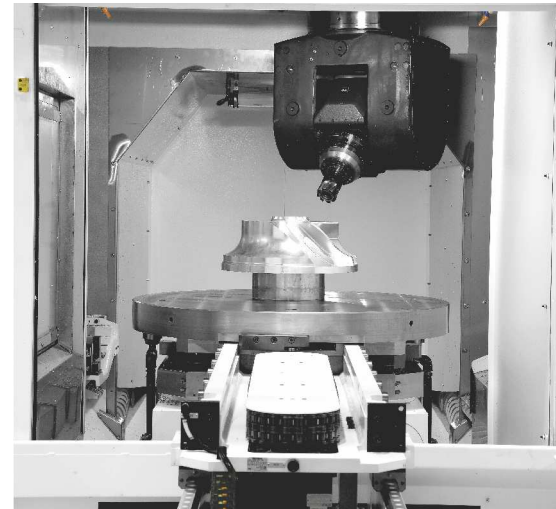

Other salient features

- Chip removal by flush coolant.
- ATC is placed out of working area and is thus protected from clogging due to dust of machining. The tools can be loaded during machining.
- Integral guarding with a large accessibility by the roof and the side allowing an easy positioning of the workpiece. Large opening of door for loading with crane.

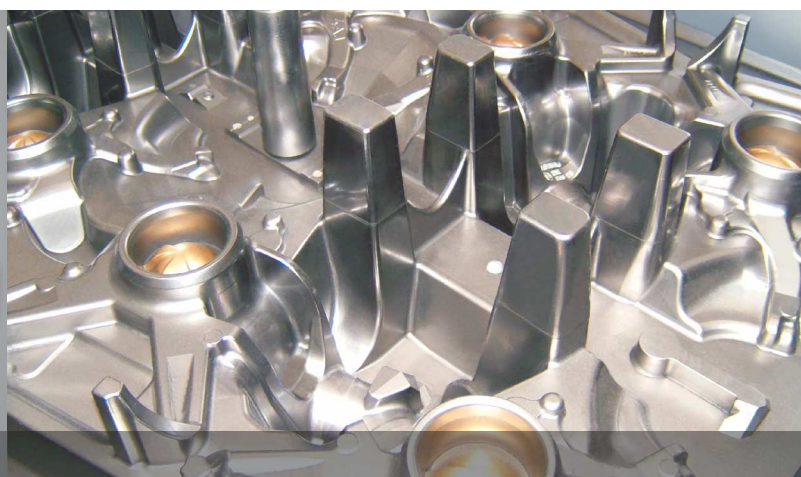
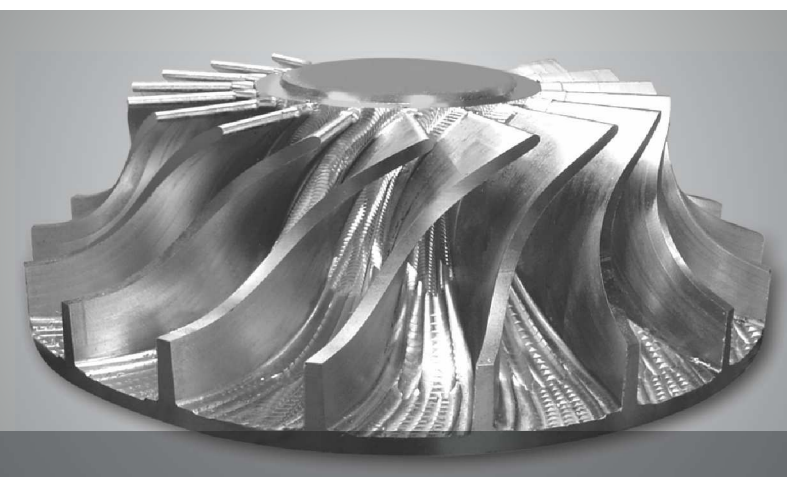



KX Large Series

Interference diagram

KX 50M

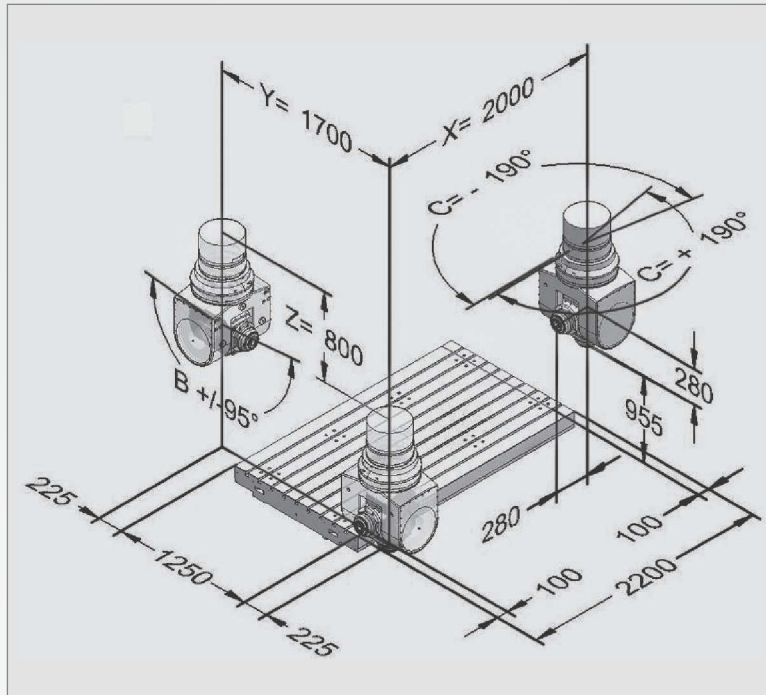

KX 50L

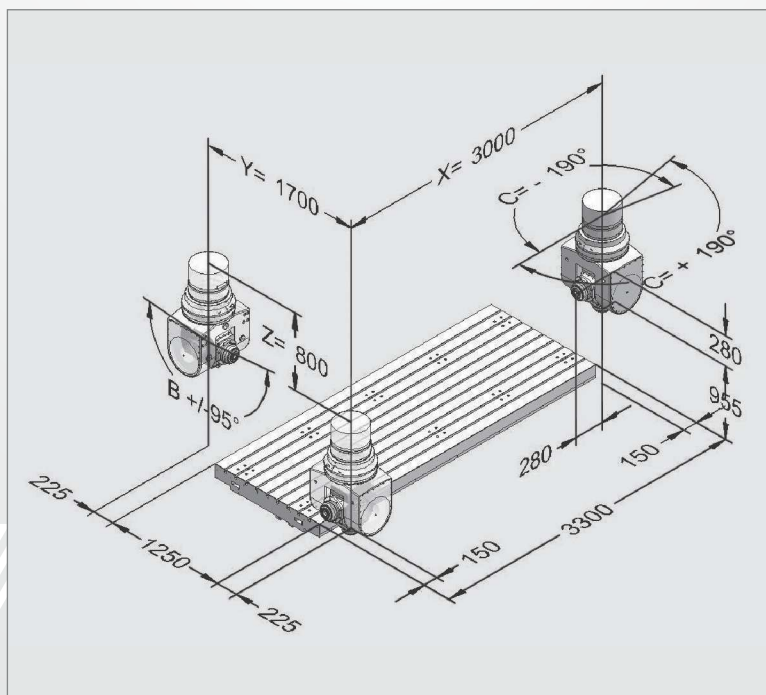



KX 100

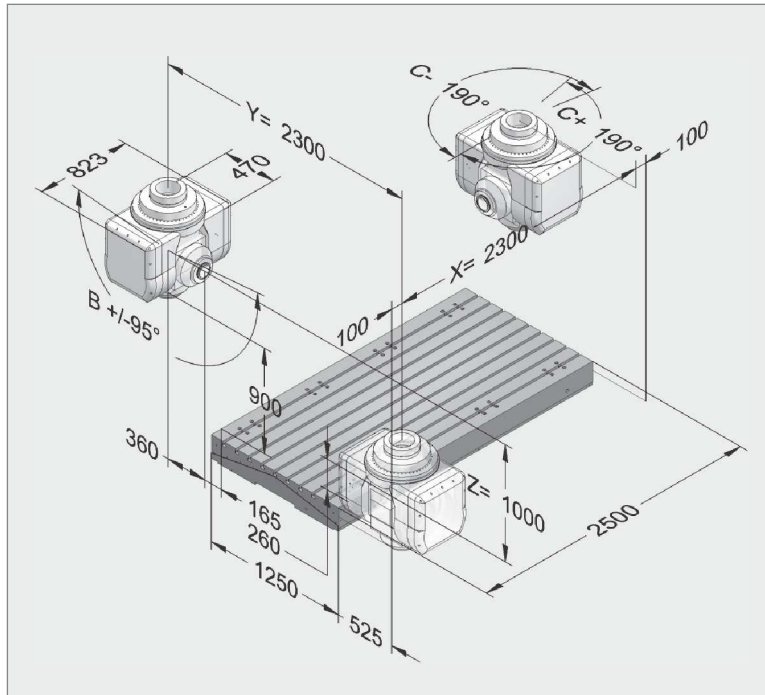

KX 200

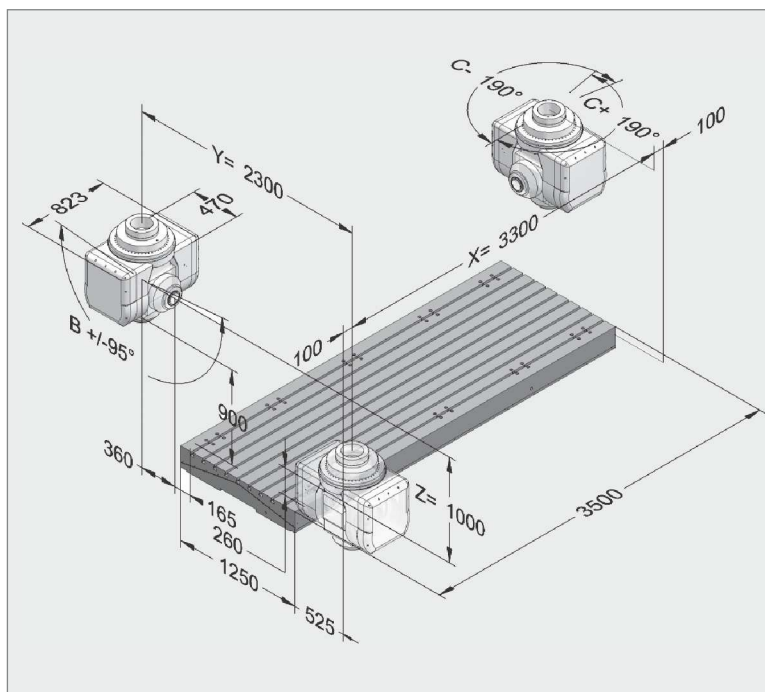

		KX 50 M	KX 50 L	KX 100	KX 200
Linear axes X / Y / Z					
Travels	mm	2.000 / 1.700 / 800	3.000 / 1.700 / 800	2.300 / 2.300 / 1.000	3.300 / 2.300 / 1.000
Rapid feedrates X / Y / Z	m/min	40	40	40	X=25-Y/Z=40
Acceleration on axis	m/s ²	4	4	4	4
			4 (*:Weight on table limited) 2,4(**)		
Vectorial acceleration	m/s ²	7	7/6,2(**)	7	7
Rotating axes B - C / Head					
B axis	deg.	+/- 95°	+/- 95°	+/- 95°	+/- 95°
C axis	deg.	+/- 190°	+/- 190°	+/- 190°	+/- 190°
Rotation	rpm	100	100	30	30
Acceleration on axis	rd/s ²	12	12	6	6
Table					
Dimension : Lenght x Width	mm	2.200 x 1.250	3.300 x 1.250	2.500 x 1.250	3.500 x 1.250
Admissible load	kg	4.000	2.500(*) 6.000	6.000	9.000
			(**):Acceleration limited)		
Quantity of slots		9	9	9	9
Slot : reference / others	mm	18H7 / 18H12	18H7 / 18H12	22H8 / 22H12	22H8 / 22H12
Distance between slots	mm	125	125	125	125
Spindle					
Speed	rpm	20.000	20.000	18.000	18.000
Taper		HSK 63A	HSK 63A	HSK 63A	HSK 63A
Power (S6 / S1)	kW	75 / 60	75 / 60	30 / 20	30 / 20
Torque (S6 / S1)	Nm	75 / 60	75 / 60	240 / 160	240 / 160
Characteristic speed	rpm	9.950	9.950	1.200	1.200
Tool Magazine					
Housings		30	30	40	40
Tool length	mm	300	300	300	300
Tool weight	kg	8	8	8	8
Weight in the magazine	kg	120	120	160	160
Tool diameter	mm	ø90	ø90	ø100	ø100
Tool changing time :					
tool/tool - chip/chip	sec	9 / 18	9 / 18	6 / 20	6 / 20
Accuracy					
- Linear axes (X / Y / Z)					
Positioning uncertainty (P)	mm	0,007	0,007	0,007	0,007
Repeatability (Ps medium)	mm	0,004	0,004	0,004	0,004
- Rotating axes (B - C)					
Positioning uncertainty (P)	sec	10	10	10	10
Repeatability (Ps medium)	sec	5	5	5	5
Coolant					
Flow	l/min	10	10	30	30
Pressure	bar	3	3	5	5
Tank	litres	375	375	1.000	1.000

Optional equipments

- Different spindle options
- Tool changer with 40/60/100 pockets
- Coolant 50 bar
- Coolant by micro spraying
- Air blast
- Part probe
- Tool probe
- Electrical cabinet climatization
- Oil extraction system
- Oil separator
- Sight glass
- Graphite dust removal system
- Pressurization of measuring scales

Note : All above informations are subject to change arising out of continuous product improvement. The standard description, accessories and technical datas conforms to our pricelists, not to the photo of machines shown in the catalogue.



Jyoti Group



www.jyoti.co.in

FRANCE : HURON GRAFFENSTADEN
 156, Route de Lyon - BP 30030
 67401 Strasbourg-IIIkirch Cedex
 Tel +33 (0)3 88 67 52 52
 Fax +33 (0)3 88 67 69 00
 www.huron.eu / commercial@huron.fr

CANADA : HURON CANADA
 408 Isabey
 St-Laurent, Québec H4T 1V3
 Tel +1 514 44 84 873
 Fax +1 514 44 84 875
 www.huron.fr / infocanada@huron.fr

GERMANY : HURON FRÄSMASCHINEN
 Siemensstrasse 56 - 70839 Gerlingen
 Tel +49 (0)7156 92836 12
 Fax +49 (0)7156 92836 50
 www.huron.de / verkauf@huron.de